

PT4500W-TK



High Bright 15" Teleprompter with SDI Widescreen Monitor & Travel Case



What's Included

- 1x Teleprompter Base
- 1x Hood Frame
- 1x Silicone Hood w/ Canvas Shroud
- 1x Counterweight
- 1x Tall Riser
- 1x Medium Riser
- 1x DSLR Riser
- 2x L-Shaped Hex Keys
- 2x 1/4-20 Camera Screws
- 1x 15 in. Widescreen Monitor
- 1x Power Adapter
- 1x 70/30 15 in. Glass
- 1x Digital Copy of Prompter Pro4
- 1x Hard Travel Case



Teleprompter Assembly Setup

Step 1

Place the teleprompter glass frame on a flat surface and remove the four screws as shown.

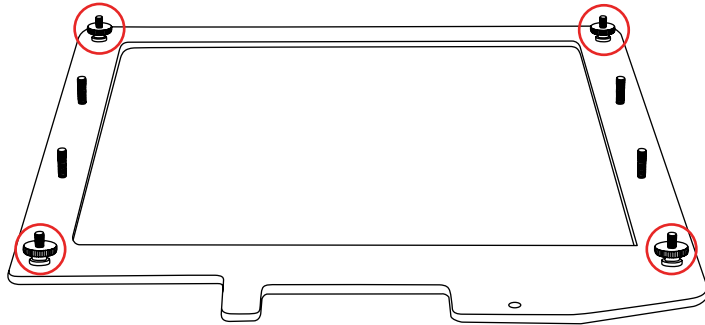

Step 2

Align and attach the teleprompter hood with the 8 screw pegs from the teleprompter frame.

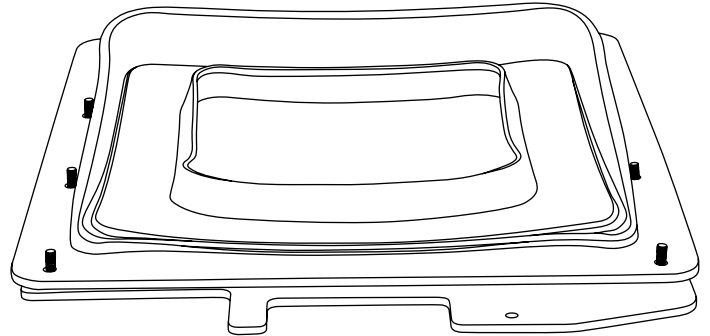

Step 3

The metal frame is directional. Make sure the thicker side is on top and the slimmer side is on the bottom.

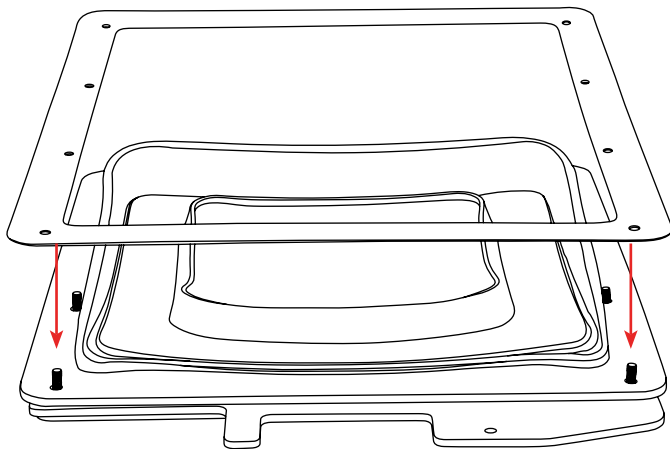

Step 4

Put the washers on before tightening the screws. The washers and 4 additional screws are inside a bag on the bottom foam.

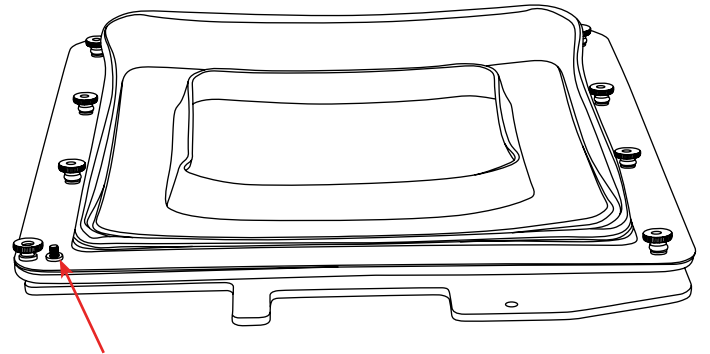

Step 5

Extend the teleprompter hood open and attach teleprompter boot using the clips. It is suggested to align the seam with the bottom of the teleprompter hood.

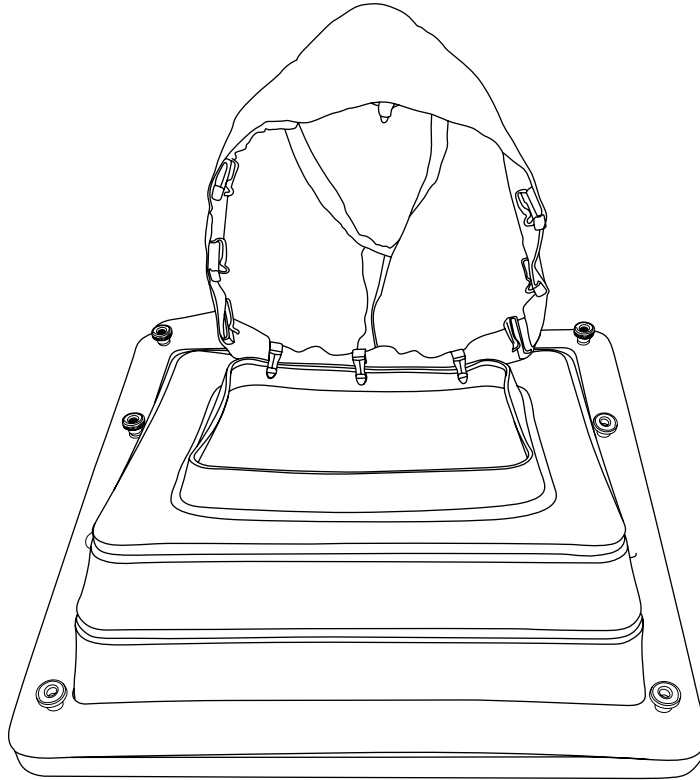

Step 6

Remove the monitor mounts from the teleprompter base using the included larger 4mm hex key to loosen from the 15mm rods.

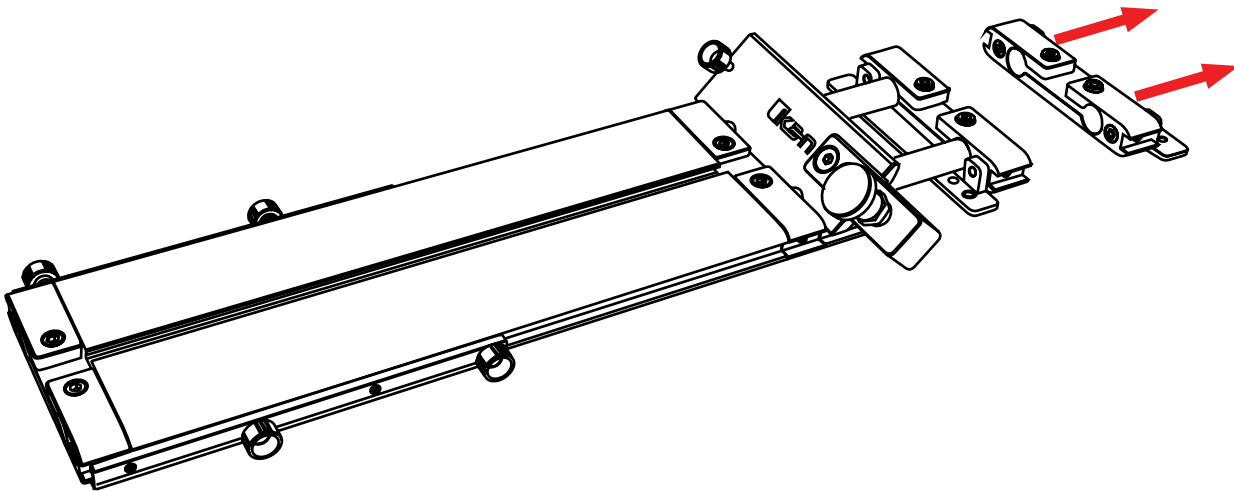

Step 7

Attach the monitor mounts on the back of the monitor's VESA compatible threads using the 4 included screws and provided 2mm hex key.

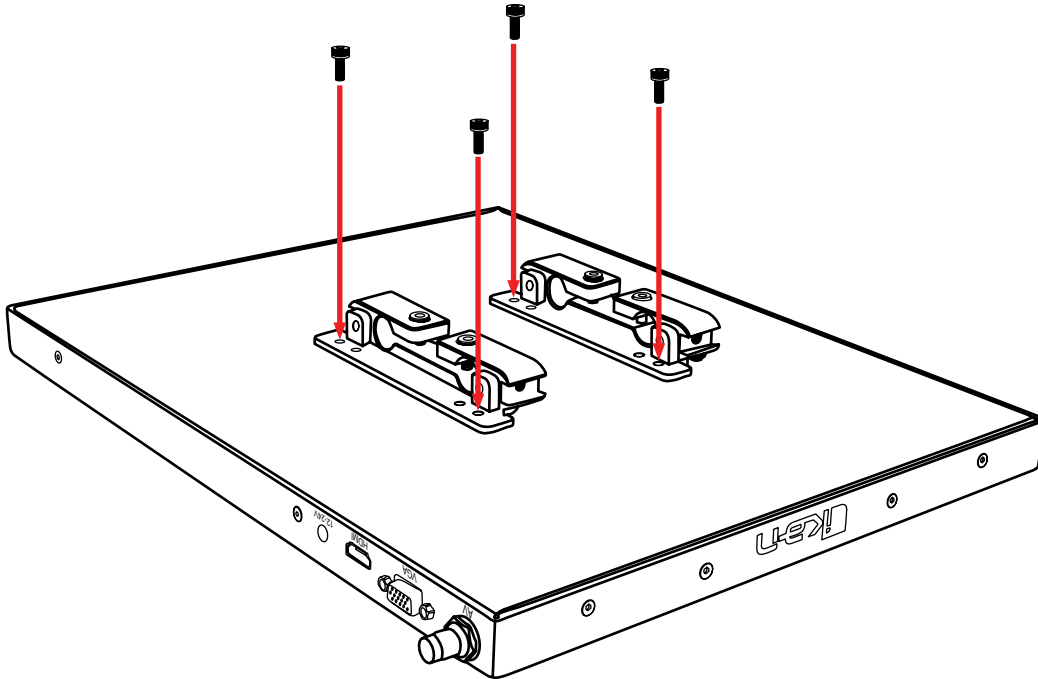

Step 8

After the monitor mounts are attached, adjust the 15mm rods to accommodate the monitor. Leave about 1 inch of room for the teleprompter bracket. Make sure the 15mm rods go through both set of monitor mounts. Please ensure that all screws are properly tightened after inserting the monitor.

SAFETY NOTE Make sure to leave at least 2 inches of the rods inside the teleprompter base.

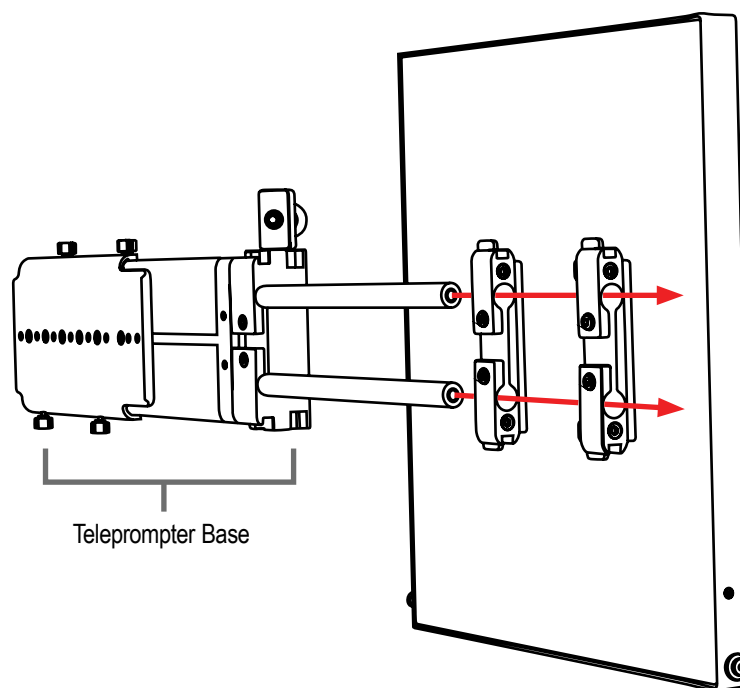

Step 9

While sliding the teleprompter bracket into the slot of the teleprompter base pull on the red knob to allow the bracket to fully slide in.

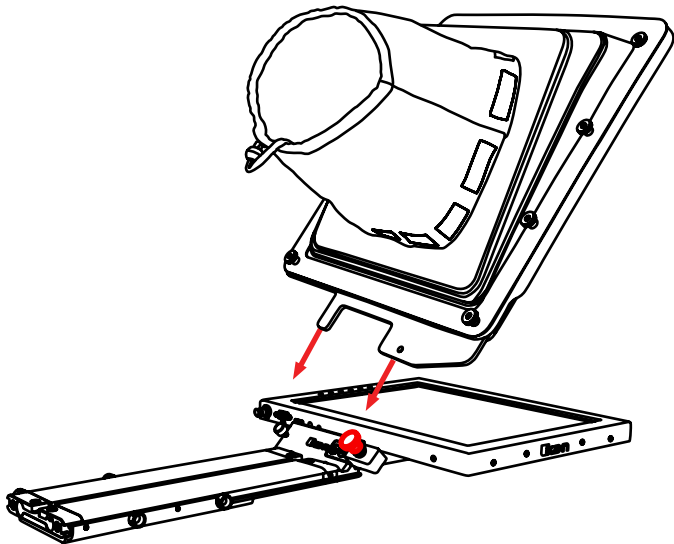

Step 10

Once the bracket is in place, tighten the side screw to lock in place. Double check and make sure all the screws are tightened with the included hex keys.

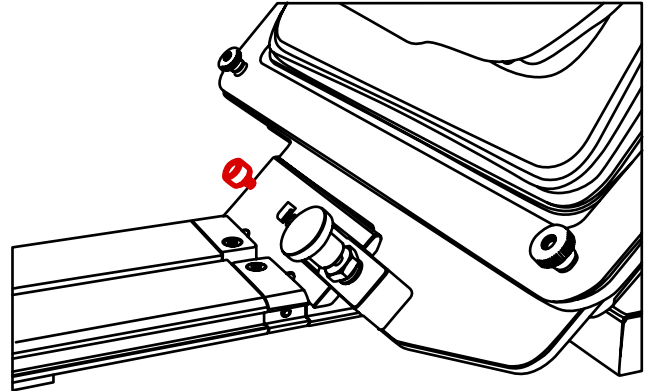

Step 11 (optional)

Should the teleprompter be too front heavy, you can attach the included counter weight on the back of the teleprompter base.

Foam Case

To make your teleprompter more portable, we packed it in a reusable, high-quality SKB rolling hard case.



Monitor Ports

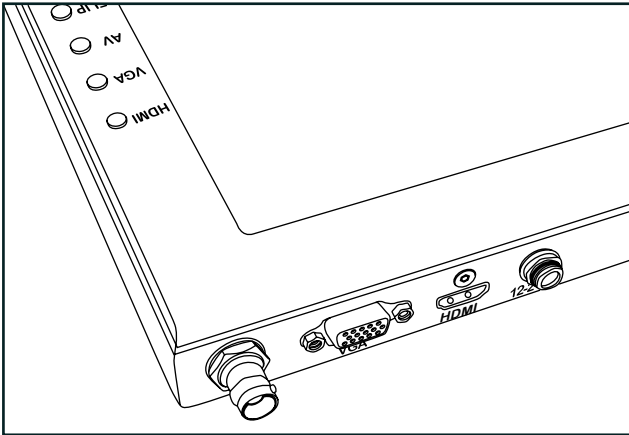

- BNC – SDI Input
- VGA – Video Graphics Array DE15 Connection
- HDMI – High-Definition Multimedia Interface Input Connection
- Power Port – 12-24v Input

Monitor Menu Settings

Video Config

- Contrast (White Level)
- Brightness (Black Level)
- Tint (Chroma Hue)
- Chroma (Chroma Saturation)
- Sharpness (Detail)
- RGB Setup – Manually configure RGB
- Return

System Config

- Menu Duration – Set duration of how long menu stays on screen
- Video Ratio – Set screen aspect ratio 16:9 or 4:3 (4:3 is native resolution, 16:9 will create black bars)
- Flip-H – Assign toggle button to flip image horizontally
- Flip-V – Assign toggle button to flip image vertically
- Reset – Factory reset
- Return

PC Setup (Only available for VGA)

- H-Position – Adjust horizontal position
- V-Position – Adjust vertical position
- Auto – Monitor automatically adjust position
- Return

Exit

How to set-up FLIP button feature:

1. Press MENU button
2. Navigate to SYSTEM CONFIG.
3. Navigate to FLIP-V or FLIP-H
4. Change FLIP-V and/or FLIP-H to "ON"
5. Exit MENU
6. The FLIP button should now be activated and can be pressed to mirror the image Horizontally or Vertically
7. When FLIP-H is ON, the image will flip Horizontally
8. When FLIP-V is ON, the image will flip Vertically
9. If both are ON, the FLIP button will toggle both Horizontal and Vertical flip

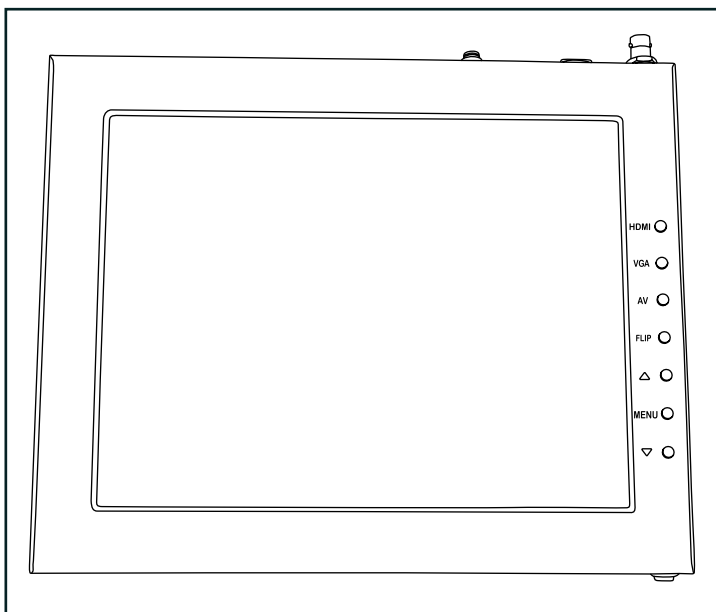

- HDMI – Switch HDMI input
- VGA – Switch to VGA input
- SDI – Switch to composite SDI input
- Flip – Toggle image flip
(Can be set to horizontal, vertical, or both via menu)
- Up Arrow – Toggle up to adjust setting
- Menu – Access to monitor settings
- Down Arrow – Toggle down to adjust setting



Watch our VIDEO TUTORIAL on how to assemble Ikan Professional Teleprompters:

ikancorp.com/15-in-videos/



Specifications

15 in. Teleprompter

Riser Plate Height	Medium: 3.74 in. High: 5.31 in. / DSLR: 6.29 in./160mm
Length of Rods	15mm x 400mm
Build Material	Chassis: Anodized Aluminum Rods: Carbon Fiber
Reading Range	17 ft./5.18m
Beamsplitter Ratio	70/30
Beamsplitter Shape	Rectangular
Beamsplitter Material	Glass
Tripod Mounts	8 x 1/4 in. -20 Female 6 x 3/8 in. -16 Female
Product Weight w/ Low Plate	24.11 lbs.
Product Weight w/ Medium Plate	24.51 lbs.
Product Weight w/ High Plate	24.64 lbs.
Weight	22 lb
Product Weight w/ DSLR Plate	24.01 lbs.
Sliding Range	5.9 in./150 mm

15 in. Teleprompter Monitor

Aspect Ratio	16:9
Maximum Brightness	1000 cd/m2
Screen Size (Diagonal)	15 in.
Tally Input	RJ45
Tally Pin out	3-Pin (5V, Red GND, Green GND)
Mount	VESA 100mm
Video Inputs	SDI, HDMI, VGA
Input Voltage	DC 12v
Power Consumption	26.5W
Product Weight	3.73 lbs.
Product Dimensions	15.7 x 10.6 x 1.1 in.
Native Resolution	1920 x 1080
Viewing Angle	178° (H) / 178° (V)
Build Material	Aluminum Chassis
Image Flip	Horizontal: Yes Vertical: Yes

Travel Case

Internal Dimensions	22 x 17 x 12.75 in.
External Dimensions	24.34 x 19.47 x 14.38 in.
Weight	18.75 lbs.
Carry/Transport Options	Handle, Retractable Handle, Wheels (Built-In)
Color	Black
Security Lock	Accepts Padlock
Water Resistance	Waterproof
Build Material	Polypropylene

Optional Accessories

- PT4500-G** Replacement Glass for both PT4500-V2
- M15W** 15" High Bright Widescreen Talent Monitor (for PT4500-SDI-V2)
- PT15-SDI-V2** 15" High Bright 4:3 Monitor (for PT4500-SDI-V2)
- PT-CASE-V2** Rolling Hard Case for PT4500-SDI-V2 Teleprompter
- PT-CASE-15TM** Hard Case for 15" Talent Monitor



Supported Video Signals

HDMI:

1080p @ 50, 25, 59.94, 60, 23.976, 24, 29.97, 30 Hz
1080i @ 50, 59.94, 60 Hz
720p @ 50, 59.94, 60 Hz
480p @ 59.94 Hz
576p @ 50, 59.94 Hz
576i @ 50 Hz
1920x1200 @ 60 Hz
1600 x 1200 @ 60 Hz
1400x1050 @ 60 Hz
1280x1024 @60 Hz
1280x960 @ 60 Hz
1360x768 @ 60 Hz
1280x768 @ 60 Hz
1024x768 @60 Hz
800x600 @ 60 Hz
640x480 @ 60 Hz

Learn More

More dynamic information at official website: www.ikancorp.com

Support

Contact email: support@ikancorp.com

CONDITIONS OF WARRANTY SERVICE

- Free service for one year from the day of purchase if the problem is caused by manufacturing errors.
- The components and maintenance service fee will be charged if the warranty period is expired.

Free Service will not be Provided in the Following Situations:(*Even if the product is still within the warranty period.)

- Damage caused by abuse or misuse, dismantling, or changes to the product not made by the company.
- Damage caused by natural disaster, abnormal voltage, and environmental factors, etc.

©2024 Ikan International. All rights reserved.



Pinout Diagram for Tally Light

Tally Light Pinout:

GND: Connects to the ground of the device or system.

R: Connects the red tally light

G: Connects the green tally light

Y: Connects the yellow tally light

NC: Stands for "Not Connected" Disregard these pins.

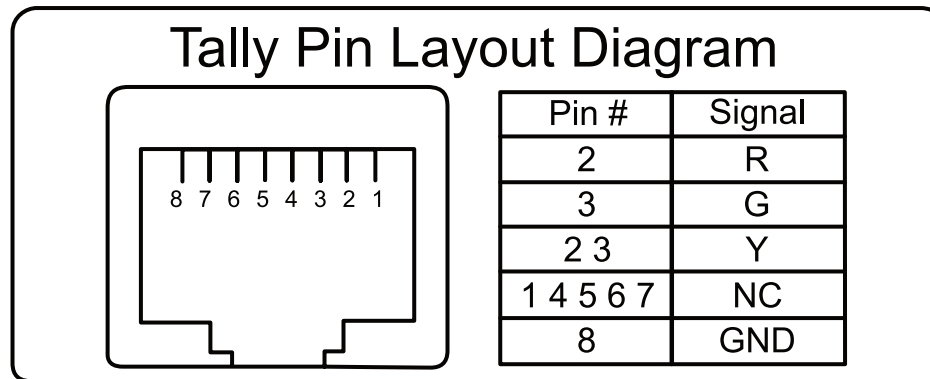

Learn More

More dynamic information at official website :www.ikancorp.com

Support

Contact email: support@ikancorp.com

©2024 Ikan International. All rights reserved.

